

本公司有权保留对机器技术参数的修改，恕不另行通知。
Dafa reserve the right to change technical characteristics without further notice.

黄旭承印 电话 1395847672



温州拓懿机械有限公司
Wenzhou Tuoyi Machinery Co.,ltd.

瑞安市大发机械有限公司

地址：浙江省平阳县滨海新区万洋众创城D14-27栋
邮编：325200
销售热线：0577-65519993 65517970
传真：0577-65517969
手机：13738357707
联系人：安涛
邮箱：radfjx@126.com
网址：www.dafamachine.com

DAFA MACHINERY CO.,LTD.

Add: Building D14-27, Wanyang Zhongchuang City, Binhai New Area,
Pingyang County, Zhejiang Province, china Zip Code: 325200
Tel: +86-577-65519993 65517970
Fax: +86-577-65517969
Mb: 13738357707
Contacts: Antao
E-mail: radfjx@126.com
Web: www.dafamachine.com

Dafa Machinery
透明膜包装机专业制造商
Transparent Film Packaging Machine

Dafa MACHINERY CO.,LTD.
瑞安市大发机械有限公司

What we can do for you?

In the transparent film packaging machinery industry,
DAFA adhere to the integrity and quality of corporate philosophy,
Continuous innovation and development,
We not only design a comprehensive packaging solution for you,
but also provide you with high efficiency, intelligence, low consumption equipment,
Choose DAFA, we can do more, better!



我们能为您做什么?

在透明膜包装机械行业中，
大发企业坚守诚信和质量的企业理念，
不断地创新和发展，
我们不仅能为您设计全面的包装解决方案，
还能为您提供高效、智能、低耗的机械设备，
选择大发，我们可以做到更多，更好！

目录 Contents

01	企业简介 Brief Introduction
02	销售网络 Sales Network
03-04	BTB-200A 透明膜包装机 Transparent Film Packaging Machine
05-05	BTB-200B 透明膜包装机 Transparent Film Packaging Machine
06-06	BTB-180 全自动透明膜包装机 Automatic Transparent Film Packaging Machine
07-08	BTB-300A 透明膜包装机 Transparent Film Packaging Machine
09-10	BTB-400A 透明膜包装机 Transparent Film Packaging Machine
11-12	BTB-100 装盒机 Automatic Cartoning Machine
13-14	ZH-100 自动装盒机+三维包装生产线 Automatic Cartoning Machine+Three-dimensional Packaging Production Line
15-16	BTB-150 自动平面贴标机 Automatic Plane Labeling Machine
17-18	BTA450+BM500 全自动L型热收缩包装机 Automatic L Type Heat Shrink Packaging Machine
19	BM-500 恒温收缩包装机 Constant Temperature Shrink Packaging Machine
20	BM-500L/700L 恒温收缩包装机 Constant Temperature Shrink Packaging Machine

Quality First Sci-tech Leading

关于我们

瑞安市大发机械有限公司是一家集研发，制造，销售于一体的科技型机械企业，拥有一批资深的机械研发及销售团队。

大发机械历经十多年的不断发展和创新，现生产的大发牌三维包装机系列，热收缩包装机系列及包装材料等产品在行业中享有极高荣誉和口碑，尤其在化妆品行业深受客户认可。

大发机械成立以来一直注重客户服务，创建了一套快捷、完善的客服流程和系统，并已陆续在东北、华南、西南等区域设立办事处，为客户提供周到及时的服务，让客户感受到了服务无距离。

我们承诺：为每一个客户负责到底，为每一个客户创造价值。“为每一个客户提供稳定、高效的自动化后道包装解决方案”为使命，并以“通过技术与创新，让大发企业成为包装机行业的首选品牌”为远景，真诚地邀请您：同绘蓝图，共创辉煌！

ABOUT US

Ruian Dafa Machinery is a collection R & D, manufacturing, high-tech machinery and sales enterprise, has a group of experienced mechanical R & D and sales team.

Dafa machinery through more than 10 years continuous development and innovation , now the production of Dafa licensing three-dimensional packing machine series, heat shrink packaging machine and packaging materials products enjoy a high honor and reputation in the industry, especially in the cosmetics industry recognized by customers.

Since the establishment of Dafa machinery, we pay attention to customer service , to create a quick and perfect customer service processes and systems, and has been in the northeast, Southern China, southwest regional offices, provide customers with timely and thoughtful service, let customers feel the service without distance.

Our commitment: is responsible for in the end for each customer, create value for every customer. "To provide automated stability, efficient for each customer after packaging solutions" for the mission, and to "through technology and innovation, let the Dafa to become the preferred brand of" packaging machine industry for the long-term, sincerely invite you: with a blueprint for painting, create brilliant!

包装材料 Packaging Material



BOPP烟膜片材
Smoking Membrane Sheet



BOPP烟膜卷材
Smoking Membrane Coiled Material



POF对折热收缩膜
POF Film



防伪金拉线
Anti-counterfeiting Gold Bracing Wire



大发机械拥有十几年的包装机械制造经验，我们以市场为导向，不断改革创新，研发和生产出高质量和高性能的设备，我们凭借高品质、优服务，赢得了国内外客户认可，产品行销全球！

DAFA Machinery has ten years of experience in manufacturing packaging machinery, We continue to reform and innovate with the market as the guidance. R & D and production of high quality and high performance equipment, We rely on high quality and excellent service. Won the domestic and foreign customers recognition, product marketing global!

BTB-200A

Transparent Film Packaging Machine

透明膜包装机

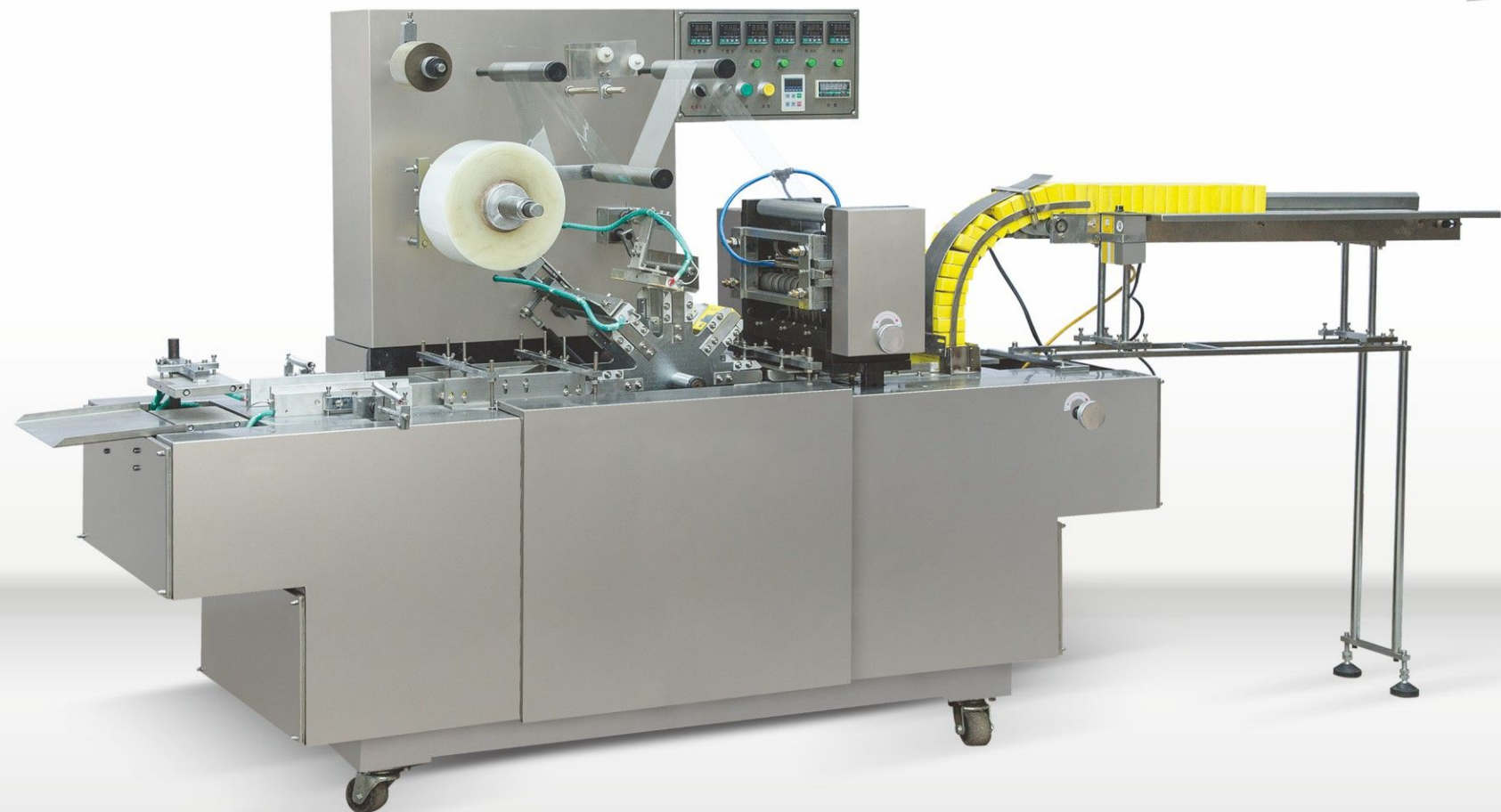

用途

该机主要适用于医药、食品、保健品、化妆品、音像制品、等行业方形盒装物品的外表装潢包装。如药盒、口香糖、保健品、茶叶、方糖、安全套、橡皮、蚊香、香烟、磁带、VCD (CD) 光盘、扑克牌、透明皂、方型电池、软盘等起到了防伪、防潮的作用，并提高产品档次，增加了产品附加值。本机可与装盒机联动生产。

特点

1. 结构紧凑合理，性能稳定先进，操作维护简便。
2. 采用多功能数显变频器，无级变速。
3. 模具更换方便，灵活。
4. 具有自动供料，自动计数等功能。
5. 传动部分设有各类保护装置及故障提示。
6. 设有试机送膜离合器，不浪费包装材料。

Usage

This machine is adapted to medicines , foods , health care products , cosmetics , audio and video products and other related square boxes decorating . such as : medicine box ,chewing gum , health care products , tea , sugar ,condoms ,rubber , mosquito-repellent incense ,cigarettes , tapes , CDS VCD (CD) , playing CARDS , transparent soap , batteries , floppy disk played anti-counterfeiting , etc , and Improved the product specification , increased value-added products . This machine can be linked with the boxes machine production .

Features

1. Compact structure, stable performance, convenient operation and maintenance.
2. Using the multi-function digital converter, stepless speed changed.
3. Mould replaced convenient and flexible.
4. With automatic feeding materials and counting function.
5. Transmission parts have protection devices and troubleshooting tips.
6. With trial film feeding clutch to saving packaging materials.

主要技术参数/Main Technical Parameters:

型号	Model	BTB-200A
包装速度	Packaging Speed	40-80盒/分钟 cases/min
包装材料	Packaging Material	BOPP烟膜及防伪金拉线 BOPP film and anti-fake gold arrows
包装尺寸	Packaging Size	长(length)50-160mm 宽(width)20-100mm 厚(thickness)8-50mm
设备尺寸	Machine Size	2000×790×1550mm (L X W X H)
设备重量	Machine Weight	(about)600Kg
电源	Power Supply	220V 50HZ
总功率	Total Power	4.5kw

注意：
产品以实物为准，如有变化，恕不另行通知。

Note:
Products are subject to actual products, if change without prior notice.

BTB-200B

Transparent Film Packaging Machine

透明膜包装机

主要技术参数/Main Technical Parameters:

型号	Model	BTB-200B
包装速度	Packaging Speed	30-80盒/分钟 cases/min
包装材料	Packaging Material	BOPP烟膜及防伪金拉线 BOPP film and anti-fake gold arrows
包装尺寸	Packaging Size	长(length)50-160mm 宽(width)20-100mm 厚(thickness)10-50mm
设备尺寸	Machine Size	2800×790×1550mm (L X W X H)
设备重量	Machine Weight	(about)750Kg
电源	Power Supply	220V 50HZ
总功率	Total Power	4.5kw

注意: 产品以实物为准, 如有变化, 恕不另行通知。 Note: Products are subject to actual products, if change without prior notice.



特点

1. 结构紧凑合理, 性能稳定先进, 操作维护简便。
2. 采用多功能数显变频器, 无级变速。
3. 模具更换方便, 灵活。
4. 具有自动供料, 自动计数, 光电跟踪。
5. 传动部分设有各类保护装置及故障提示。
6. 无包装物不下膜, 不浪费包装材料。

用途

该机主要适用于散装扑克、沙琪玛、报事贴、便笺纸、威化饼干等散状或多件物体集合的三维包装。

Usage

This machine is adopt to bulk poker, sachima, Newspaper stick, scribbling paper, wafer biscuit and other related bulk things' three dimension bag .

Features

1. Compact structure, stable performance, convenient operation and maintenance.
2. Using the multi-function digital converter, stepless speed changed.
3. Mould replaced convenient and flexible.
4. With automatic feeding materials , counting function and photocell followed .
5. Transmission parts have protection devices and troubleshooting tips.
6. No packaging not sending film, do not waste packaging materials.

BTB-180

Automatic Transparent Film Packaging Machine

全自动透明膜包装机

功能特点

BTB-180型是大发机械有限公司经过精心设计成就的一款新型机、电、气于一体的全自动变频调速型三维透明膜裹包机。本机采用台达变频器和国产电器元件控制技术组成, 成功地解决了推包、折角、下膜、成型等一系列不稳定因素中的问题。更换不同的模具即可包装不同大小规格的盒装产品, 取代了那种只能包装一种规格的转盘式的包装设备。包装出来的产品平整、美观、密封性能好和环保等作用。并且得到广大用户的一致认可, 更是如今生产企业后续包装人力资源不足的必选设备。

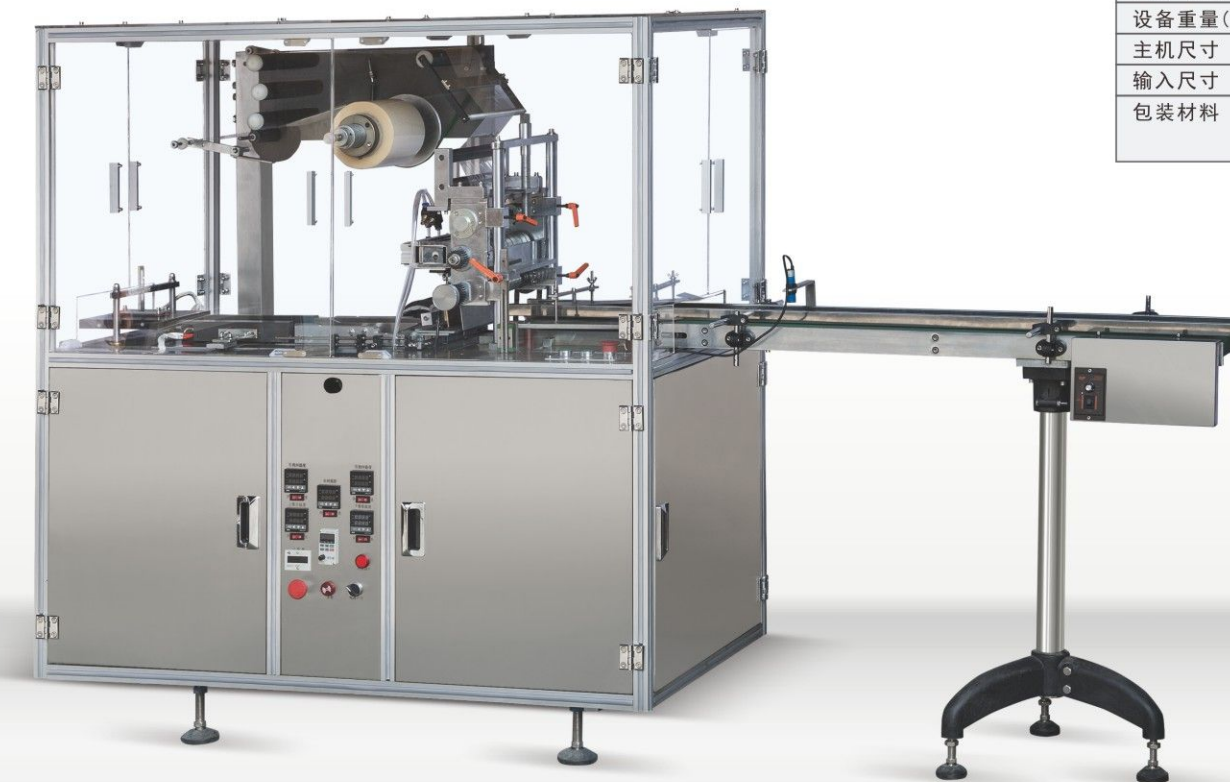

主要技术参数/Main Technical Parameters:

型号	Model	BTB-180
包装速度	Packaging Speed	60-100包/分 (根据产品大小可调速使用)
包装尺寸	Packaging Dimensions	L 40-200mm W 20-100mm H 8-35mm
耗电功率	Power Consumption	1.2kw
总功率	Total Power	3.5kw
电压	Voltage	220v-50Hz
工作气压	Working Air Pressure	0.2Mpa
设备重量(约)	Equipment Weight(approx.)	约300kg
主机尺寸	Machine Dimensions	1450*690*1470mm
输入尺寸	Conveying Dimensions	800*150*80mm
包装材料	Packaging Material	双面热封BOPP. PVC. PVDC膜。各种不干胶粘贴拉线。卷膜尺寸: 内径Φ70外径Φ320mm。

注: 如果设备外观及功能更新恕不另行通知, 均以实物为准, 气源自备。本机可直接联接装盒机
Note: Products are subject to actual products, if change without prior notice.

用途介绍

本机广泛运用于扑克牌、保健品、药品、化妆品、擦炮、染发剂、烟嘴、文具等行业中各种直角盒装物品的单包透明膜三维自动裹包。

Usage

This machine is widely used in playing cards, health products, pharmaceuticals, cosmetics, cannon wipes, hair dyes, cigarette holders, etc. In stationery and other industries, all kinds of right-angle boxed articles are automatically wrapped in three-dimensional transparent film with single package.

BTB-300A

Transparent Film Packaging Machine

透明膜包装机



用途

该机主要适用于医药、食品、保健品、化妆品、音像制品、等行业方形盒装物品的外表装饰包装。如药盒、口香糖、保健品、茶叶、方糖、安全套、橡皮、蚊香、香烟、磁带、VCD (CD) 光盘、扑克牌、透明皂、方型电池、软盘等起到了防伪、防潮的作用，并提高产品档次，增加了产品附加值。本机可与装盒机联动生产。

Usage

This machine is adapted to medicines, foods, health care products, cosmetics, audio and video products and other related square boxes decorating, such as: medicine box, chewing gum, health care products, tea, sugar, condoms, rubber, mosquito-repellent incense, cigarettes, tapes, CDS VCD (CD), playing CARDS, transparent soap, batteries, floppy disk played anti-counterfeiting, etc, and Improved the product specification, increased value-added products. This machine can be linked with the boxes machine production.

特点

1. 结构紧凑合理，性能稳定先进，操作维护简便。
2. 采用多功能数显变频器，无级变速。
3. 模具更换方便，灵活。
4. 具有自动供料，自动计数等功能。
5. 传动部分设有各类保护装置及故障提示。
6. 设有试机送膜离合器，不浪费包装材料。

Features

1. Compact structure, stable performance, convenient operation and maintenance.
2. Using the multi-function digital converter, stepless speed changed.
3. Mould replaced convenient and flexible.
4. With automatic feeding materials and counting function.
5. Transmission parts have protection devices and troubleshooting tips.
6. With trial film feeding clutch to saving packaging materials.

主要技术参数/Main Technical Parameters:

型号	Model	BTB-300A
包装速度	Packaging Speed	30-50盒/分钟 cases/min
包装材料	Packaging Material	BOPP烟膜及防伪金拉线 BOPP film and anti-fake gold arrows
包装尺寸	Packaging Size	长(length)50-240mm 宽(width)20-140mm 厚(thickness)10-80mm
设备尺寸	Machine Size	2100×850×1650mm (L X W X H)
设备重量	Machine Weight	(about)700Kg
电源	Power Supply	220V 50HZ
总功率	Total Power	4.5kw

注意：
产品以实物为准，如有变化，恕不另行通知。

Note:
Products are subject to actual products, if change without prior notice.



BTB-400A

Transparent Film Packaging Machine

透明膜包装机

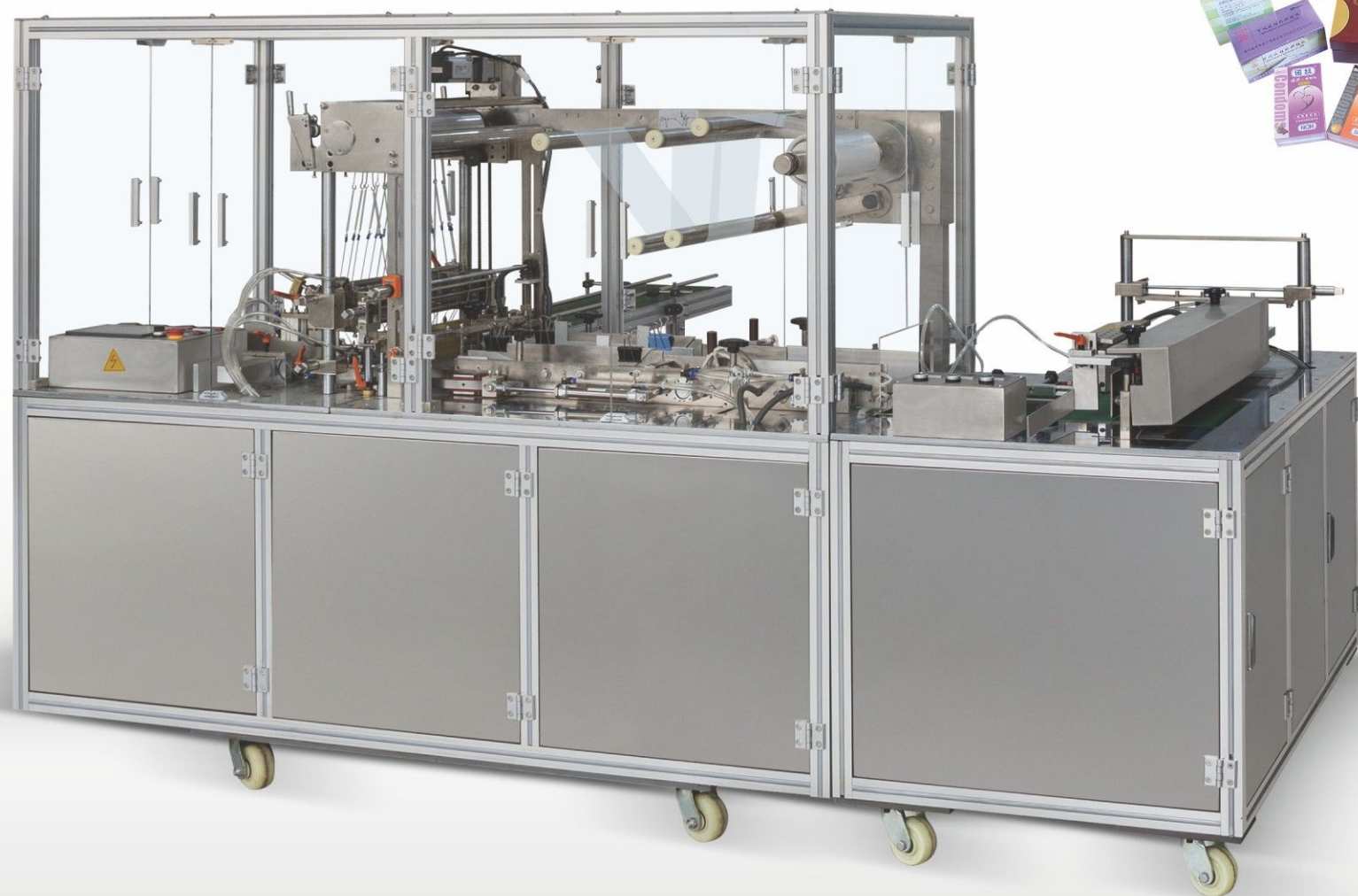

用途

该机广泛适用于药品、食品、保健品、化妆品、日用品、文具用品、扑克等行业中的各种盒式物品的中包集合或单盒全封闭自动包装。经该机包装的产品具有“三防三提高”之功能，即防伪、防潮、防尘；提高产品档次、提高产品附加值、提高产品外观装潢质量。该机采用进口PLC控制，机电气一体化运行系统。性能可靠，使用方便，是国内先进的盒式中包集合或较大物品的三维包装设备。本机可提供装盒机联动生产装置。

Usage

This machine is adapted to medicines, foods, health care products, cosmetics, daily necessary, playing cards and all kinds of boxes which is including with single or double fully automatic packaging. The products that after this kind of machinery to package have special functions "three -against and three-improved ". It is against counterfeit, against moisture, against dust, and improved the level of products, improved product added value, improved the product's exterior decoration. This machine controlled by PLC, electrical integration system. Reliable performance, easy to use, it is the domestic advanced cassette of three-dimensional objects or larger set of packaging equipment. This machine can provide boxes linkage of production equipment.

主要技术参数/Main Technical Parameters:

型号	Model	BTB-400A	BTB-400A(加大型)
生产效率	Packaging Speed	20-50包/分钟 bags/min	15-30包/分钟 bags/min
包装尺寸范围	Packaging Size	长Length of the bag 100-280mm 宽Width of the bag 50-200mm 高Thickness of the bag 20-90mm	长Length of the bag 100-400mm 宽Width of the bag 50-240mm 高Thickness of the bag 20-120mm
电源	Power Supply	220V.50-60HZ	220V.50-60HZ
电机功率	Motor Power	4Kw	4Kw
加热功率	Heating Power	3.7KW	3.7KW
输送架	Transport Plane	1800×300×750mm	1800×300×750mm
外形尺寸	Overall Dimensions	2000X920X1650mm (L×W×H)	2100X1020X1650mm (L×W×H)
重量	Machine Weight	900Kg	1000Kg
气源	Air Pressure	7.5kg/cm ³	7.5kg/cm ³

注意：
产品以实物为准，如有变化，恕不另行通知。

Note:
Products are subject to actual products, if change without prior notice.

BTB-100

Automatic Cartoning Machine

装盒机



产品概述

BTB-100型全自动装盒机是集光、电、气、机一体化的高科技装盒机械设备，该款装盒机设备适用于药品装盒、食品装盒、日用品装盒、化妆品装盒、保健品装盒、五金电器装盒、玩具装盒、汽配装盒等各系列盒装产品的机械化包装。该款纸盒包装设备能高效率完成自动下料、自动下盒、自动入产品、自动封盒、自动打印批号等繁杂装盒过程，为客户减少大量人力成本。BTB-100型装盒机可单独完成产品装盒包装，也可同其他包装设备联线使用。

主要性能特点

1. 采用自动送料、开盒、入盒、打批号、封盒、剔废等的包装形式，操作简单，运行平稳，噪音低。
2. 采用PLC和人机界面自动控制系统，无级变频调速，效率高，耗能低。
3. 采用国际知名品牌电气元件，性能稳定可靠。
4. 采用机械过载自动停机功能，确保人机安全。
5. 自动剔除缺陷包装物或缺说明书的包装成品，确保包装成品率。
6. 采用故障显示报警系统，便于维护和处理故障。
7. 可根据客户要求选配热熔胶机，采用热熔胶喷胶封盒。
8. 可与枕式包装机，贴标机，热收缩包装机，束带捆包机等其他设备实现对接联动生产。

Product Description

The BTB-100 automatic cartoning machine is a high-technology carton packing equipment, it has been widely used for boxes packing in medicine, food, daily necessities, hardware, electronics, toys, auto. parts and other industries. With automatic goods feeding, box opening, goods encasing, box NO. Printing, box sealing and scrap rejecting, the machine can be easily operated and reduce labor costs for customers. The machine can work well as independent, and also can operate with other packing machines to be as a packing machine line.

Main Performances and Structure Features

1. With automatic goods feeding, box opening, goods encasing, box NO. Printing, box sealing and scrap rejecting, the machine can be easily operated, running smoothly and low noisy
2. With VFD speed controlling, tough screen and PLC controlling system, the machine must be high efficiency and energy saving.
3. With electrical appliances and pneumatic components of the world's top brands, the machine will be more stable working performance.
4. With overload protection device, the machine can ensure itself and workers more safer.
5. With the automatic detection and tracking system, the machine will reject the non-goods or non-leaflet packages.
6. With the alarm system for mechanical defects, it will be much easier to maintain the machine.
7. According to customer's requirement, the hot melt glue machine can be equipped to seal the boxes.
8. Running well as independent, the machine also can operate with the pillow packaging machine, labeling machine, heat-shrink packing machine or other machines to be as a packing machine line.

主要技术参数/Main Technical Parameters:

型号	Model	BTB-100
装盒速度	Encasing Speed	30-100Bxs/min
材质要求	Quality Requirement	30-350g/m ²
尺寸范围	Dimension Range	(60-220)x(15-160)x(15-85)mm(L x W x H)
全系列装盒机可包尺寸范围	Dimention Range of All Boxes Packed	(45-400)x(15-260)x(15-100)mm(L x W x H)
工作压力	Working Pressure	≥0.6Mpa
耗气量	Air Consumption	20M3/h
电源	Power Supply	AC220V/380V 50HZ
总功率	Total Power	1.5KW
外形尺寸	Overall Dimension	3500 X 1400 X 1800mm(L x W x H)
重量	Machine Weight	1000kg

注意：产品以实物为准，如有变化，恕不另行通知。 Note: Products are subject to actual products, if change without prior notice.

ZH-100

Automatic Cartoning Machine+Three-dimensional Packaging Production Line

自动装盒机+三维包装生产线

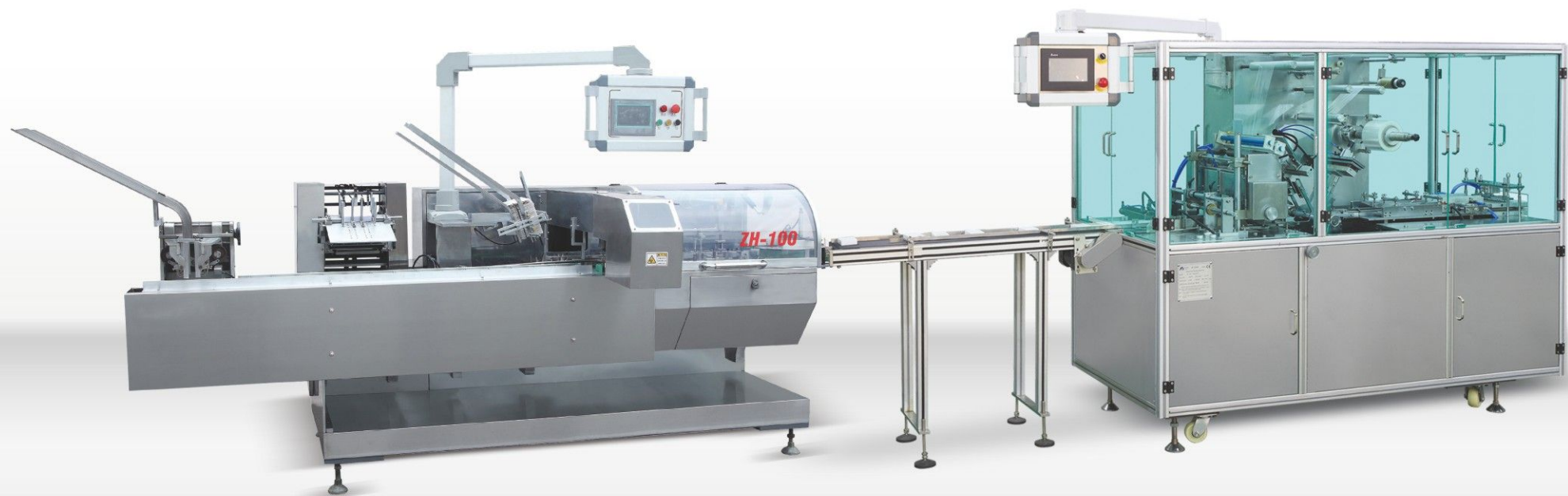
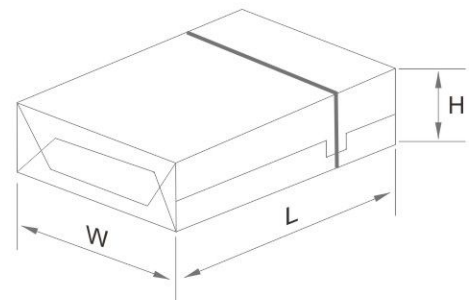

用途

该机是我公司研制的新产品，应用范围广，效率高，运行稳定，可一机多用，适用于药品、食品、化妆品的包装。

特点

1. 能自动完成说明书的折叠，纸盒成型、打开、版块装盒、批号打印、封口等工作。并可配热熔胶系统完成热熔胶封口。
2. 该机采用PLC控制。光电监控各部位动作，运行中出现异常，能自动停机显示原因，以便及时排除故障。
3. 机架内部装有主驱动电机和离合制动器，并在机板上装有各部分传动系统扭矩过载保护器，可以在超负荷的情况下，实现主驱动电机与各传动部分脱开，确保整机的安全。
4. 该机设有智能检测装置。无物料自动不下说明书、不下纸盒，在检测过程中发现废品（无药版、说明书）即在出口处被剔除，保证产品质量完全达到合格要求。..
5. 该机可以单独使用，亦可与泡罩包装机及其它设备联动使用，形成成套生产线。
6. 该机可根据用户的不同使用要求，可更换包装规格，调节及调试简便，即适用于大批量单一品种的生产，同时又可以满足用户小批量多品种的生产。

主要技术参数/Main Technical Parameters:

型号	Model	ZH-100
电源	Power Supply	AC380伏三相五线制供电50Hz,总功率1.5千瓦
外形尺寸	Overall Dimensions(L×W×H)	2900×1350×1600mm
整机重量	Machine Weight	1300kg
生产能力	Production Capacity	主机运行速度60-100盒/分钟 折纸机运行速度60-100张/分钟
耗气量	Gas Consumption	20立方米/小时（压力大于0.6兆帕）
包装材料	Packing Material	纸盒质量：250-350克/平方米（视纸盒尺寸而定）规格：最大尺寸（长×宽×高）200×120×60毫米,最小尺寸（长×宽×高）55×35×15毫米
说明书	Instructions Book	纸张质量：55-65克/平方米,规格：最大尺寸（长×宽）240×170毫米,最小尺寸（长×宽）110×90毫米
压缩空气	Compressed Air	0.5MPa流量大于0.6m ³ /min

注意：产品以实物为准，如有变化，恕不另行通知。 Note: Products are subject to actual products, if change without prior notice.

Usage

This machine is a new product developed by our company, wide application range, high efficiency, stable operation, one machine with multifunction, applicable to the pharmaceutical, food, cosmetics packaging.

Features

1. This machine auto complete folding, the box forming and opening, edition piece cartoning, batch number printing work. And can be equipped with hot melt adhesive system to complete the hot melt adhesive sealing.
2. This machine adopts PLC control. The action of each part of the photoelectric monitoring, abnormal operation, can Automatic shutdown display reasons, so as to eliminate the fault.
3. The inner part of the machine frame is provided with a main driving motor and clutch brake, and the machine plate is provided with each part of the torque overload protection device of transmission system, in the case of overload, the realization of the main drive motor and the drive parts is disengaged, ensure the safety.
4. The machine is equipped with intelligent detection device. No material not put-down instructions, not put-down carton, In order to for the before device linkage work. Found waste in the detection process (no drug version, instructions) were excluded, to ensure the quality of products fully meet requirements.
5. This machine can be used alone, but also with the blister packaging machine and other equipment linkage used, shape into a set of production line.
6. The machine according to different use requirements of users, replaceable packing specification, adjustment and commissioning Simple, is suitable for mass production of a single variety, and users can satisfy the small Batch production of more varieties.

BTB-150

Automatic Plane Labeling Machine

自动平面贴标机



用途

适用于在各种物品的上平面贴标签或不干胶膜，如书本、文件夹、盒子、PE袋子、纸箱等，更换覆标机构可适用于不平整表面贴标，广泛应用于大件产品的平面贴标，规格范围大的平面类物体贴标。可选配打码机或喷码机到贴标头，可实现在标签上打印生产日期、批号和喷印条码等信息；可选配喷码机到输送带，可实现贴标前或贴标后在产品上喷印生产日期、批号、条码等信息。

Usage

Applicable to the various items on the plane affixed labels or stickers, such as books, folders, boxes, PE bags, cartons, etc., replace the label body can be applied to the uneven surface labeling, widely used in large products Flat labeling, the scope of a wide range of flat-type object labeling. Optional code printer or inkjet printer to the labeling head, the label can be printed on the production date, batch number and printing bar code and other information; optional inkjet printer to the conveyor belt can be achieved before labeling or labeling After the production of printing on the product date, batch number, bar code and other information.

主要技术参数

- ★贴标精度：±1mm (不含产品、标签误差)；
- ★贴标速度：60-200件/分钟（与产品、标签尺寸有关）；
- ★适用产品尺寸：长：40mm~400mm 宽：100mm~250mm高：1mm~150mm
- ★适用标签尺寸：长度：6mm~300mm 宽度（底纸宽度）：15mm~150mm
- ★整机尺寸：约1800mm×780mm×1500mm（长×宽×高）；
- ★适用电源：220V/50HZ；
- ★整机重量：约250Kg

Main Technical Parameters

- ★Labeling Accuracy: ± 1mm (excluding product, label error);
- ★labeling Speed: 60-200 pieces / minute (with the product, the size of the label);
- ★Applicable Product Size: Length: 40mm ~ 400mm Width: 100mm ~ 250mm Height: 1mm ~ 150mm
- ★Applicable Label Size: Length: 6mm ~ 300mm Width (bottom paper width): 15mm ~ 150mm
- ★Machine Size: about 1800mm × 780mm × 1500mm (length × width × height);
- ★Power Supply: 220V / 50HZ;
- ★Machine Weight: about 250Kg

BTA450+BM500

Automatic L Type Heat Shrink Packaging Machine

全自动L型热收缩包装机



用途

适用于软件、食品、化妆品、印刷、制药及地板、陶瓷、饮料、五金等行业的大批量收缩包装。

Usage

Suitable for large quantity shrink wrapping industries such as software, foodstuff, cosmetics, printing, pharmacy, flooring, ceramics, beverage and beer etc.

特点

BTA-450是一款全自动无人化操作的“L”型封切机,广泛用于批量生产包装的流水作业,工作效率高,自动送膜打孔装置和手动调节的导膜系统以及手动调节的进料输送平台,适用不同宽度及高度的产品。

1. 封刀采用美国杜邦特弗龙涂层抗粘耐高温铝合金刀,封口不会开裂,不会焦化、不冒烟零污染。
2. 配有进口检测光电,水平、垂直检测各一组,便于切换选择,对于薄与小的包装物,可轻易完成封口包装作业。
3. 自动送料,长度亦能经由电眼和计时器的组合,自动调节。配有感应马达,自动卷取废料。
4. 当包装物尺寸变更时,调整非常简单,不用换模具与制袋器。
5. 不同大小的产品还可以搭配组合包装,以达到促销效果。
6. 温控器采用原装“欧姆龙”数显温控器,内置PID功能,封刀温度极为灵敏与精确,可随意设定。不必担心温度不精确伤及产品,封刀自身还带有自动保护功能,有效防止误切包装物。
7. 该机封切部分装有有机玻璃保护罩,并带有自动报警功能,大大提高操作者的安全性。
8. 整套机器真正实现与生产线的无人化操作连接。

Features

BTA-400 It is a fully automatic L sealer,widely used in pipelining work for large quantity package with high work efficiency,installed with pin hole device,adjustable film feeding system and adjustable conveying table,adapted to different width and height of the products.

1. Adopts heat resistant alloy cutter plated Teflon,results in good sealing ,without melting the film and any smoke pollution.
2. Assembles one horizontal and one erect sensor for the entrance to the sealer it is easy to switch over ,even for some thin products,it is also easy to pack them.
3. The length of film feeding,controlled by magic eye and counter,also fixes an inductive motor for collecting wasted film automatically.
4. When pack different sizes of products ,it is simple to adjust,need not to exchange any molds or any bag making device.
5. To pack different size of products together for sales promotion effect.
6. Adopts OMRON digital temperature controller with PID function,sealing temperature is extremely sensitive and accurate,can set temperature optionally ,the cutter itself has a protective function,avoid from damage the products.
7. The machine fixes an organic safty glass cover,with alarm function,so that the operator is safe.
8. The machine can be connected with the production line, which is no need additional operators.

主要技术参数/Main Technical Parameters:

型号	Model	BTA-450	BM-500
最大包装尺寸	Max Packing Size	(L+H)=500mm (W+H)=430mm (H)=130mm	(L)700×(W)450×(H)250mm
最大封口尺寸	Max Sealing Size	(L)550×(W)450mm	(L)1200×(W)500×(H)300mm(炉腔尺寸)
包装速度	Packing Speed	15~30包/分钟 packs/min	30~50包/分钟packs/min
电源及总功率	Electric Supply & Power	220V/50Hz 1.3kw	380V/50Hz 12kw
使用气源	Air Pressure	5.5kg/cm ³	/
机器重量	Machine Weight	300kg	220kg
机器外形尺寸	Overall Dimensions	(L)1850×(W)1000×(H)1600mm	(L)1350×(W)750×(H)1500mm

注意:产品以实物为准,如有变化,恕不另行通知。 Note:Products are subject to actual products, if change without prior notice.

BM-500

Constant Temperature Shrink Packaging Machine

恒温收缩包装机



产品概述

采用滚轴式输送带，滚筒外包耐高温硅胶管每根均可自由转动。不锈钢加热管，内部三层隔热，大功率循环电机，双向热循环风使热量均匀，恒温。收缩温度及输送速度可随意调节，确保收缩产品达到最佳效果。热风循环通道，以回风式的热炉内胆结构，热风只在炉腔内运行，有效防止热量散失。

Product Introduction

The machine adopts roller conveyor, high temperature resistant silicone tube each drum outsourcing can free rotation. Stainless steel heating tube, internal three layer heat insulation, high power cycle motor, bi-directional thermal cycling wind heat evenly, constant temperature. Temperature and conveying speed can be adjusted, ensure contract products to have best packing effect. Hot air circulation channel, return type heat furnace tank structure, hot air only run within the furnace chamber, prevent heat loss effectively.

主要技术参数/Main Technical Parameters:

型号	Model	BM-500
电源及总功率	Electric Supply & Power	380v/50-60Hz 12kw
包装速度	Packing Speed	0~15m/min
收缩炉腔尺寸	Chamber Size	(L)1000×(W)450×(H)250mm
机器重量	Weight	260kg
机器外形尺寸	Overall Dimensions	(L)1300×(W)700×(H)1400mm
适用收缩膜	Shrink film	PE、POF、PVC、PP

BM-500L/700L

Constant Temperature Shrink Packaging Machine

恒温收缩包装机



产品概述

本机采用滚轴式输送带，滚筒外包耐高温硅胶管每根均可自由转动。同时采用不锈钢加热管，内部三层隔热，双向热循环风使热量均匀，恒温。进口双变频调速，可调整吹风速度和输送速度快慢，以达最佳效果。带有三层防爆玻璃观察窗，可直视炉内产品收缩情况。

Product Introduction

The machine adopts roller conveyor, high temperature resistant silicone tube each drum outsourcing can free rotation. Stainless steel heating tube, three layers of internal insulation, bi-directional thermal cycling wind heat evenly, constant temperature. Imported double frequency conversion, can adjust the blowing and conveying speed to achieve the best effect. With three layers of explosion-proof glass observation window to easy watch packing result of each product.

主要技术参数/Main Technical Parameters:

型号	Model	BM-500L	BM-700L
电源及总功率	Electric Supply & Power	380v/50-60Hz 15kw	380v/50-60Hz 16kw
包装速度	Packing Speed	0~30m/min	0~30m/min
收缩炉腔尺寸	Chamber Size	(L)1500×(W)500×(H)300mm	(L)1500×(W)700×(H)300mm
机器重量	Weight	400kg	500kg
机器外形尺寸	Overall Dimensions	(L)1800×(W)1100×(H)1300mm	(L)1800×(W)1300×(H)1300mm
适用收缩膜	Shrink film	PE、POF、PVC、PP	PE、POF、PVC、PP

